

THE PRODUCTION OF ELEMENT 102

G. N. FLEROV, S. M. POLIKANOV,* A. S. KARAMYAN,† A. S. PASYUK, D. M. PARFANOVICH, N. I. TARANTIN, V. A. KARNAUKHOV, V. A. DRUIN, V. V. VOLKOV, A. M. SEMCHINOVA, Yu. Ts. OGANESYAN,* V. I. KHALIZEV, G. I. KHLEBNIKOV, B. F. MYASOEDOV,‡ and K. A. GAVRILOV*

Submitted to JETP editor August 1, 1959

J. Exptl. Theoret. Phys. (U.S.S.R.) **38**, 82-94 (January, 1960)

New experiments for the production of element 102 and the investigation of its nuclear properties are described. Pu^{241} and Pu^{239} targets were bombarded with accelerated O^{16} ions. Nuclear emulsions were used to record the radioactive decay of element-102 atoms. Alpha decay of the new isotope (most probably 102^{253}) was observed, having a half-life between 2 and 40 sec and energy of 8.9 ± 0.4 Mev. Careful analysis of possible background sources indicated that the background level is much lower than the observed effect.

INTRODUCTION

TRANSURANIUM elements have hitherto been produced principally by subjecting uranium and plutonium to prolonged bombardment in nuclear reactors. The atomic number of the target nuclei was gradually increased through successive neutron captures followed by beta decay; elements up to fermium ($Z = 100$) were produced in this manner. It has thus far not been possible to synthesize still heavier elements in the same way because larger values of Z are accompanied by a rapid reduction of nuclear lifetimes with respect to alpha decay and spontaneous fission, with the consequent sharply reduced probability for the formation of beta-active intermediate products, as a result of whose decay the nuclear charge would be increased.¹

Further progress became possible with the development of techniques for accelerating multiply-charged ions. These ions can be used to increase the charge of the initial elements by several units at a time, thus avoiding the previously inevitable accumulation of intermediate products. However, even when multiply-charged ions are used the synthesis of new transuranium elements is an extremely difficult experimental task. The fundamental difficulty lies in the fact that the reactions leading to the production of a new element have extremely small cross sections. Fissility increases with the atomic number of the transuranium elements. An excited compound nucleus

resulting from the fusion of an accelerated heavy ion with the target nucleus disintegrates principally through a fission process; decay through neutron emission, thus generating atoms of a new element, occurs in only a negligible fraction of the events. The experimenter therefore has only a small number of atoms available to use in identifying the new element and in determining its properties. The short lifetimes of these newly-formed isotopes are a second source of difficulty. Rapid decay hampers and sometimes entirely prevents the identification of a new element through ordinary chemical procedures.

In 1957 and 1958 several laboratories attempted to produce element 102 by using multiply-charged ions. An international group of Swedish, American and British scientists reported the synthesis of the element during the summer of 1957.² Among the reaction products of a curium target irradiated with C^{13} ions accelerated in the Stockholm cyclotron an alpha-active isotope was detected which emitted 8.5-Mev alpha particles and possessed a half-life of ~ 10 min. The total number of alpha particles detected with this energy was only 20. The investigators believed that they had produced element 102 with mass number 253 or 251; however at the University of California Radiation Laboratory these results were not reproduced, in spite of maintenance of identical conditions with much stronger ion beams.³

The 150-cm cyclotron of the U.S.S.R. Academy of Sciences Institute of Atomic Energy was used in our work on the synthesis of element 102, the first results being obtained in the autumn of 1957. Targets made of Pu^{241} ($100 \mu\text{g}/\text{cm}^2$) and of Pu^{239} ($300 \mu\text{g}/\text{cm}^2$) were irradiated with O^{16} ions ac-

*Joint Institute for Nuclear Research.

†Deceased.

‡Institute for Geochemistry and Analytic Chemistry, Academy of Sciences, U.S.S.R.

celerated to ~ 100 Mev. Since it was assumed that the half-lives of isotopes of element 102 which might be produced through the reaction of O^{16} ions with plutonium would be very short, we worked out a special physical technique instead of a chemical procedure for identifying the new element.

In the experiments with the Pu^{241} target eighteen 8.5-Mev alpha particles were detected. When Pu^{239} was bombarded 8 energetic particles were observed. The effect was thus smaller by a factor of 7 when converted to identical target thickness and identical bombarding period. After a number of control experiments we concluded that these alpha particles must be associated with the decay of an isotope of element 102, with probable mass number 251 – 253, produced when Pu^{241} was bombarded with O^{16} ions. A short account of these experiments has already been published.⁴

In May, 1958 a group of workers at the University of California published a report of experiments on the production of another isotope of element 102.⁵ After Cm^{246} was bombarded with C^{12} ions the American investigators used a radiochemical technique to separate Fm^{250} , which under the given conditions could have resulted from the alpha decay of 102^{254} having a half-life of 3 sec.

The present paper reports further experiments performed at the Institute of Atomic Energy from April to September, 1958. We aimed to determine more precisely the nuclear properties of the produced element-102 isotope and to study the background more thoroughly.*

EXPERIMENTAL PROCEDURE

1. Ion Acceleration

In the present experiments, as previously, the targets were bombarded in the internal beam of the 150-cm cyclotron. Quintuply-charged O^{16} ions were produced directly in a special ion source⁶ and were accelerated to 100 Mev. The ion source had been perfected through an improved design of the discharge chamber and enhanced cooling and stability. The power used in the gaseous discharge had been raised to 100 kw. Table I shows the properties of the ion beams which resulted from these improvements.

Since the cyclotron had been designed for work with protons, deuterons and helium ions ($m/e = 1$ or 2) its employment for the acceleration of quintuply-charged O^{16} ions ($m/e = 3.2$) required a highly strengthened current in the magnet coils

TABLE I. Properties of Heavy-Ion Beams

Ions	Charge	Intensity, μ amp	Energy, Mev
C^{12} , C^{13}	4	20	94
N^{14} , N^{15}	5	2	110
O^{16} , O^{18}	5 6	3 0.1	102 130

(in order to attain the required magnetic field strength) accompanied by forced cooling. The required magnetic field configuration was obtained by means of additional shims. We know that simultaneously with quintuply-charged ions, singly-charged ions are accelerated at a multiple of the frequency. As a result of the stripping mechanism, the ion beam at the terminal radius contains, in addition to monoenergetic particles, quintuply-charged ions with a continuous energy distribution, produced in the cyclotron out of singly-charged ions. We succeeded in producing a beam in which the monoenergetic component was predominant, having an energy spread of not more than 4%.⁷

2. Recoil Technique

The procedure used to separate nuclei of element 102 from the target material was based on the collection of recoil nuclei. When a heavy bombarding particle strikes a target nucleus, the resulting compound nucleus acquires such high momentum that it may be knocked out of a fairly thick target. Ejected nuclei are caught by a suitable technique and are transferred to an emission detector. In this way a small number of the new atoms, which are usually highly radioactive, can be separated from the target material. Another advantage of this procedure is that it permits repeated bombardment of the same target.

The range of the recoil nuclei must be known before a target of optimum thickness can be prepared. In special experiments performed for this purpose thin gold foils with vacuum-deposited layers of aluminum or copper were bombarded with N^{14} ions of known energy. The radon nuclei produced in the reaction $Au^{197}(N^{14}, xn)$ were ejected from the gold and some of them entered a catcher after passing through the aluminum or copper layer. The intensity ratio of alpha-active products in the catcher and in the aluminum and copper layers of different thicknesses indicated the mean ranges for recoil nuclei in these elements. The range for atoms of element 102 produced when Pu^{241} was bombarded with O^{16} ions was estimated by using the experimental results

*A brief account of this work was given in a supplement to the report of G. N. Flerov at the Second International Conference on the Peaceful Uses of Atomic Energy in Geneva.

for the range of radon atoms in conjunction with Firsov's formula

$$R = 0.5 \frac{A_2 (A_1 + A_2)}{A_1} \frac{(Z_1 + Z_2)^{1/2}}{Z_1 Z_2} E, \quad (1)$$

where R is the atomic range in $\mu\text{g}/\text{cm}^2$; Z_1 , A_1 and Z_2 , A_2 are the atomic number and mass number of the recoil atom and medium, respectively; E is the kinetic energy of the recoil atom in kev.

Equation (1) was derived for the ranges of atoms with initial velocity $10^7 - 10^8$ cm/sec, taking into account the way in which slowing-down at such velocities is affected by the interaction between electron shells of the colliding atoms.⁸ Consideration of the electronic effect showed that in this instance description of the atomic collision required a potential that is inversely proportional to the square of the atomic separation.

While developing a technique for catching recoil nuclei we performed in 1954 qualitative experiments investigating the ranges of radioactive nuclei produced in $(n, 2n)$ and (n, p) reactions when various elements were bombarded with 14-Mev neutrons. The results indicated that the given formula satisfactorily describes the manner in which the ranges of the recoil nuclei depend on E , Z_1 , A_1 , Z_2 and A_2 .

In Table II the experimental mean ranges of nuclei produced in various reactions are compared with the ranges calculated by Eq. (1). In computing

the energies of reaction products it was assumed that a compound nucleus is formed, the momentum of the bombarding particle being transferred to the nucleus as a whole. For the recoil effect associated with the ejection of neutrons and protons from the compound nucleus angular isotropy of the emitted particles was assumed. Our data for the range of radon nuclei are in agreement with reference 9.

When the target is made of PuO_2 and the oxygen-ion energy is ~ 100 Mev a calculation indicates $500 - 600 \mu\text{g}/\text{cm}^2$ for the recoil range.

3. Apparatus for Bombarding Targets and Registering Alpha Decay of Reaction Products

Figure 1 shows the experimental setup. An oxygen-ion beam 1 impinged on a plutonium layer 2. Nuclei of element 102 with high momentum were emitted by the target and entered a thin ($\sim 2\mu$) aluminum catcher foil 6. The ion collector 5 behind the catcher of recoil nuclei was connected to the current integrator, which monitored the beam intensity during bombardments and measured the total ion flux traversing the target. The catcher was shifted at regular intervals by means of a kapron thread to a position 2 m from the target and close to photographic plate 8, which served to register alpha decay. All apparatus was located within a brass vacuum tube communicating with the cyclo-

TABLE II. Experimental Ranges of Recoil Nuclei Compared with Calculations Based on Eq. (1)

Recoil nucleus	Stopping medium	Reaction	E, kev	R_{exp} , $\mu\text{g}/\text{cm}^2$	R_{calc} , $\mu\text{g}/\text{cm}^2$
Mg^{27}	Al	$\text{Al}^{27}(n, p)$	550	300 ± 30	280
Al^{28}	SiO_2	$\text{Si}^{28}(n, p)$	500	330 ± 30	185
Cu^{62}	Cu	$\text{Cu}^{63}(n, 2p)$	250	65 ± 10	85
Ag^{106}	Ag	$\text{Ag}^{107}(n, 2n)$	150	35 ± 20	40
Sb^{120}	Sb	$\text{Sb}^{121}(n, 2n)$	150	25 ± 10	30
$\text{Rn}^{205-207}$	Al	$\text{Au}^{197}(\text{N}^{14}, 4-6n)$	6000	240 ± 50	380
$\text{Rn}^{205-207}$	Cu	$\text{Au}^{197}(\text{N}^{14}, 4-6n)$	6000	330 ± 50	490

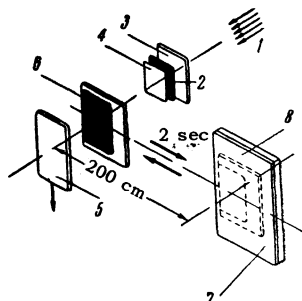

FIG. 1. Experimental setup: 1 - ion beam, 2 - plutonium layer, 3 - backing, 4 - shielding layer, 5 - ion collector, 6, 7 - catcher of recoil nuclei, 8 - photographic plate.

tron chamber. An electric motor located outside of the vacuum system was used to pull the kapron thread through a special vacuum seal. For the

purpose of estimating nuclear half-lives, the time during which the catcher remained under the target and close to the photographic plate, and also the time required to transfer it from its position in line with the target, were varied over a broad range. The minimum time required for transfer was 2 sec. An electronic time relay was used to govern the operation of the apparatus.

4. Preparation of Plutonium Targets

The targets had to satisfy two basic requirements: 1) sufficiently stable layers of active ma-

terial to withstand prolonged bombardment by an intense oxygen-ion beam; 2) sufficiently thin plutonium layers for the most efficient utilization of the recoil method.

The plutonium was deposited electrolytically or by means of tetraethylene glycol on thin nickel and niobium foils ($1 - 2 \mu$). Nickel foils were produced by thermal dissociation of nickel tetracarbonyl on a hot surface; niobium foils were rolled from very pure metal.*

A thin copper film ($\sim 50 \mu\text{g}/\text{cm}^2$) was vacuum-deposited on the plutonium layers to prevent damage of the latter. The plutonium-coated foil was clamped in a special brass holder between two well-cooled brass grids with apertures 1 mm in diameter. Satisfactory target stability was indicated by the fact that the target used in the largest number of runs was irradiated ~ 500 hours by a current of $0.5 \mu\text{amp}$ with inappreciable damage to the plutonium layers. (Granules of $\sim 0.001 \mu\text{g}$ would easily have been detected on the photographic plates.)

Uniformity of the plutonium layers and their total thickness were controlled by special apparatus,¹⁰ consisting of a miniature proportional counter and the target in question separated in a chamber by a distance of 15 cm. This chamber was filled with methane, which served as the working gas of the counter and as the absorber of alpha particles emitted by the target. By varying the gas pressure alpha particles of different energies were admitted to the counter and the target thickness was determined from range straggling. The thickness of the targets was determined to within $\sim 70 \mu\text{g}/\text{cm}^2$ of PuO_2 . Figure 2 shows the distributions of alpha-particle ranges, which characterize the uniformity and thickness of the target layers. The amount of plutonium in a target varied from 100 to $200 \mu\text{g}/\text{cm}^2$ (for $5 \times 10 \text{ mm}^2$ targets), but the presence of inactive material and the copper film resulted in a total equivalent target thickness of $700 - 900 \mu\text{g}/\text{cm}^2$ of PuO_2 .

5. Nuclear Emulsion for Registering Alpha Particles

We used the special nuclear emulsion NIKFI-T1,¹¹ which provides a high degree of discrimination between alpha-particle and proton tracks but is insensitive to beta rays. We used plates without gelatin shielding, in order to provide more precise energy determinations for alpha particles entering the emulsion from the surface. A special

*A more detailed description of the technique used in preparing the plutonium targets will be given in a separate paper.

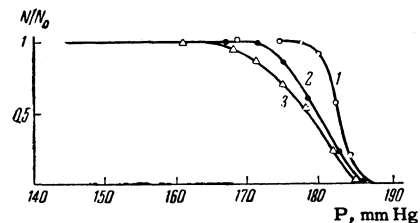

FIG. 2. Integral curves of alpha-particle range in methane for different plutonium targets: 1 - Pu^{239} , total thickness $\approx 250 \mu\text{g}/\text{cm}^2$ (of PuO_2); 2 - Pu^{241} , total thickness $\sim 750 \mu\text{g}/\text{cm}^2$; 3 - Pu^{241} , total thickness $\sim 900 \mu\text{g}/\text{cm}^2$.

technique further improved the discrimination of proton and alpha-particle tracks by means of the partial regression of latent images in water vapor. Processing in water vapor also attenuated the fog of beta and gamma rays.

It should be noted that although the catchers were very thin ($\sim 2 \mu$ aluminum foil) the beta-ray background resulting from activation of the catchers by oxygen ions was so high that NIKFI-Ya or Ilford-E1 emulsions could not be used.

A background resulting from radioactive contamination and cosmic rays accumulates in an emulsion during storage of the plates. For the purpose of removing this background the plates were treated with water vapor a few hours before experimental use until the latent images completely disappeared. The plates were kept in a vacuum before being subjected to bombardment in order to eliminate the danger of radioactive contamination from the air.

Since the plates were only 2 m distant from the targets it was necessary to attenuate the fast neutron flux which might produce an undesirable background of recoil protons and alpha particles from an (n, α) reaction. A shield consisting of 20 cm of copper and 10 cm of paraffin was therefore placed between the cyclotron chamber and the photographic plate. The background resulting from fast neutrons was then negligibly small.

The photographic plates were of considerably larger area than the catchers of recoil nuclei. Scanning of the areas which could not be reached by alpha particles from the catcher permitted direct determination of the background from the (n, α) reaction and from ThC' under the experimental conditions.

INVESTIGATION OF PLUTONIUM TARGET CONTAMINATION BY BISMUTH AND LIGHTER ELEMENTS

In discussing experiments for the production of element 102 by bombarding plutonium with accelerated O^{16} ions we have stated⁴ that bismuth

and lead impurities in the target might to some extent produce an imitative effect. This possibility was based on the fact that the bombardment with oxygen ions could produce "supershell" isotopes of astatine, radon, francium, and radium with lifetimes of a few seconds or minutes, the decay of which would yield alpha particles with energies > 8.5 Mev.

As a control, special experiments were performed to study the alpha-active reaction products produced when oxygen ions impinge on mercury, thallium, lead, and bismuth, using the same technique and conditions as in the experiments for the production of element 102.

1. Bombardment of Mercury and Thallium with Oxygen Ions

Targets consisting of a natural mixture of mercury isotopes were made by using tetraethylene glycol to deposit thin layers ($\sim 100 \mu\text{g}/\text{cm}^2$) on niobium foil. Thallium layers of the same thickness were deposited on nickel foil by vacuum evaporation. The targets were bombarded with 98-Mev O^{16} ions. The stationary time of the catcher in the beam and next to the photographic plate was 8 sec, while the transfer time was 3 sec. No alpha particles with energies greater than 8 Mev were detected, but only a group with 6.8 ± 0.2 Mev in the case of mercury and 6.5 ± 0.2 Mev in the case of thallium (Fig. 3). These elements therefore are not subject to the effect in question. Moreover, the alpha-particle groups were so intense that their presence makes it easy to detect even small traces of mercury or thallium in plutonium. It was also determined that the working plutonium targets contained less than $0.01 \mu\text{g}/\text{cm}^2$ of these elements, which therefore did not hinder the analysis of the data obtained when plutonium was bombarded with oxygen ions.

2. Bombardment of Bismuth with Oxygen Ions

The bismuth layer was deposited on a nickel backing by means of tetraethylene glycol and was bombarded under the same conditions as the mercury and thallium. The resulting alpha-particle spectrum shown in Fig. 3 reveals two intense groups, with peaks at 6.0 ± 0.2 Mev and 7.5 ± 0.2 Mev. The number of detected alpha particles with ~ 9 Mev was smaller by a factor of about 1000 than the number with ~ 7.5 Mev. From the ratio of these groups in the spectra resulting when plutonium was bombarded with oxygen we can determine the fraction of alpha particles with ~ 9 Mev that is associated with bismuth impurities. In

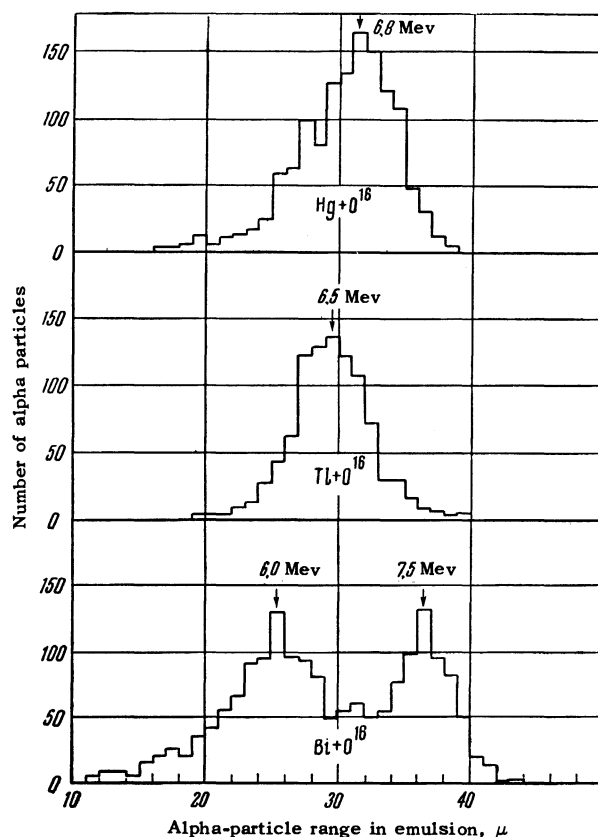

FIG. 3. Spectra of alpha particles from the bombardment of mercury, thallium, and bismuth with O^{16} ions.

the spectra obtained during the autumn of 1957 the 7.5-Mev alpha-particle group is at most 30 times as intense as the 9-Mev group, thus indicating that bismuth impurities in the plutonium target could not have produced a substantial background.

3. Bombardment of Lead with Oxygen Ions

The first experiments with lead indicated that when this element contaminates plutonium targets it may be the principal source of the background. Figure 4 shows the energy spectrum of alpha particles produced when a natural lead target was bombarded with 98-Mev oxygen ions. The reaction products are seen to include isotopes that emit alpha particles with ~ 9 Mev and have a half-life of 35 ± 10 sec.

A relatively large cross section was found for the production of an isotope emitting 9-Mev alpha particles. It was estimated that $1 \mu\text{g}$ of lead in a plutonium target could imitate the previously observed effect⁴ attributed to the decay of element 102.

A sensitive activation method was developed for the precise determination of lead impurities in plutonium targets. When lead is bombarded with carbon or oxygen ions, reactions with large

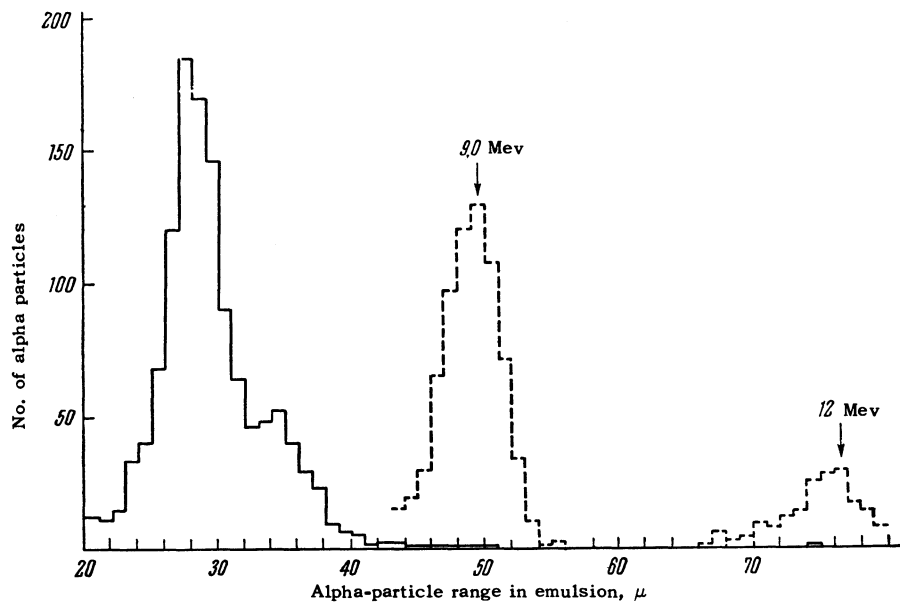

FIG. 4. Spectrum of alpha particles from the bombardment of lead with O^{16} ions. The 9-Mev and 12-Mev alpha-particle groups are shown by means of broken lines, which represent the combined results of several experiments.

cross sections result in the production of Rn^{211} , which is precisely characterized by a half-life of 16 hours and by its equilibrium with Po^{211} , which emits 7.43-Mev alpha particles. The plutonium targets were bombarded with carbon and oxygen ions and the Rn^{211} yield, measured by an ionization chamber, was used to estimate the amount of lead that was present. The technique was sensitive enough to detect as little as $0.01 \mu g$ of lead.

Since lead may be concentrated either deep within or on the surface of a plutonium target it was necessary to determine how the ratio of recoil Rn^{211} yield to that of the isotope associated with $E_{\alpha} = 9$ Mev was dependent on target thickness. Lead targets of different thicknesses were irradiated. Table III gives the ratios of 9-Mev alpha activity to Rn^{211} yield for the lead targets (with the yield ratio for a $215 \mu g/cm^2$ target taken as unity). The ratio is seen to depend strongly on target thickness. In addition to determining the amount of lead impurities in the plutonium we must therefore know its distribution over the target thickness. For this purpose we compared the relative Rn^{211} yields when plutonium targets were bombarded with oxygen and carbon ions. The same isotope Rn^{211} is produced by both kinds of ions, but since the C^{12} ion transfers consider-

ably less momentum than the oxygen ion to the nucleus the yield for the $(Pb + C^{12})$ reaction depends much more strongly on target thickness. Table III also shows the relative yields of Rn^{211} entering the catcher for the reactions $(Pb + O^{16})$ and $(Pb + C^{12})$, with the ratio for a $215 \mu g/cm^2$ lead target taken as unity.

By bombarding plutonium targets with oxygen and carbon ions we were thus able to compute their lead content and distribution and thus to determine how much of the 9-Mev alpha-particle background was attributable to lead impurities.

It must be mentioned that when lead was bombarded with oxygen ions additional products were detected which decayed with the emission of 12-Mev alpha particles.¹² This emission was used as an additional control, but because of its low intensity it provides a much less accurate method of determining the lead content than the measurement of the Rn^{211} yield.

BOMBARDMENT OF Pu^{241} AND Pu^{239} WITH OXYGEN IONS: RESULTS AND DISCUSSION

In most of the experiments with Pu^{241} , target No. 1 containing $180 \mu g/cm^2$ of plutonium was used. This target was bombarded 40 times, in each instance for a period of 3 hours, with the catcher in the beam and near the photographic plate for 8 sec and a transfer time of 3 sec (Fig. 1). As in the earlier work,⁴ alpha particles with ranges in the interval $45 - 51 \mu$ of emulsion were detected. The total number of such particles was 90.

Table IV gives the results of an activation analysis of the targets for lead impurities, for both target No. 1 and target No. 2 made of Pu^{241} , which

TABLE III.

Target thickness, $\mu g/cm^2$	215	520	1160
Yield ratio of 9-Mev alpha activity and Rn^{211} (from $Pb + O^{16}$)	1.00	1.28	1.87
Ratio of Rn^{211} yields for the reactions $Pb + O^{16}$ and $Pb + C^{12}$	1.00	1.15	1.40

TABLE IV.

Target	Pb, 215 $\mu\text{g}/\text{cm}^2$	Pu ²⁴¹ , No. 1	Pu ²⁴¹ , No. 2
Yield ratio of 9-Mev alpha activity and Rn ²¹¹ from O ¹⁶ -bombarded targets	1.00	3.5 \pm 0.5	7.0 \pm 1.0
Ratio of Rn ²¹¹ yields from targets bombarded with O ¹⁶ and C ¹² ions	1.00	1.0 \pm 0.2	0.8 \pm 0.2

will be discussed below. To make comparison with Table III easy the values for a 215 $\mu\text{g}/\text{cm}^2$ lead target are taken as unity. The comparison of the tables shows that the lead contamination of plutonium target No. 1 can account for only a fraction of the 9-Mev activity. Comparison of the Rn²¹¹ yields from bombardment with O¹⁶ and C¹² ions indicates that the lead impurities were close to the target surface. Even if it is assumed that the lead is uniformly distributed throughout the target the lead can account for at most 40% of the total number of detected 9-Mev alpha particles.

Approximately the same result, although with considerably lower accuracy, is obtained by using the characteristic 12-Mev alpha rays produced in lead by oxygen ions. For a lead target the ratio of 9-Mev to 12-Mev alpha particles is 4.0 ± 0.5 . In the experiments with the Pu²⁴¹ target No. 1 this ratio was 8.0 ± 2.0 ; this agrees with the fact that 25–45% of the 9-Mev alpha particles are attributable to lead impurities.

Scanning of the plate areas that could not be reached by alpha particles from the catcher indicated that the background from the (n, α) reaction and ThC' contamination did not exceed 5%. The total background unassociated with the production of element 102 was thus not greater than half of the observed effect.

Following further purification of the plutonium to remove lead, target No. 2 containing $\sim 100 \mu\text{g}/\text{cm}^2$ of Pu²⁴¹ was prepared; the amount of lead was thus considerably smaller than in the first target (Table IV). Figure 5 shows the region of the alpha-particle spectrum above 7.5 Mev resulting from 10 three-hour bombardments of the second target with the recording apparatus functioning exactly as previously. A total of 20 particles was found with ranges in the interval 45–51 μ of emulsion, but an activation analysis showed that only 4 of these could be attributed to lead impurities.

Alpha particles with ranges 45–51 μ have a mean energy of 8.8 Mev. It must be remembered, however, that the synthesized nuclei are ejected from the target with considerable energy (~ 6 Mev) and penetrate the catcher to a considerable

FIG. 5. Spectrum of alpha particles with energies above 7.5 Mev, from Pu²⁴¹ target (No. 2) bombarded with O¹⁶ ions.

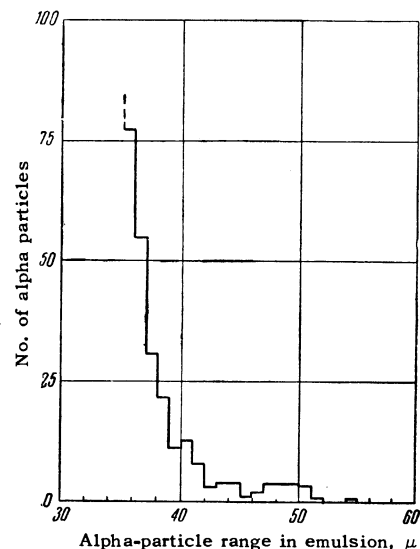

depth. Alpha particles emerging from the catcher have thus lost a portion of their energy, especially when emerging at small angles to the surface. The correction required to account for this effect was determined experimentally by measuring the ranges of alpha particles from Po²¹¹ produced by oxygen-ion bombardment of lead. When this correction is taken into account the alpha-particle group of present interest has the energy 8.9 ± 0.4 Mev.

The repetition of experiments using oxygen ions and the additional control experiments thus confirm the earlier conclusion⁴ that element 102 is produced when Pu²⁴¹ is bombarded with oxygen ions.

In order to determine the half-life of the element-102 isotope we performed a series of 39 three-hour bombardments in which the transfer time of the catcher from the target to the photographic plate was 10, 100, and 250 sec, respectively, with equal lengths of time in the beam and adjacent to the plate. Unfortunately the first target was used; the lead impurities hindered exact determination of the half-life for the activity of interest. It can be stated, however, that all activity with ranges 45–51 μ , and therefore the isotope of element 102, decayed with a half-life < 40 sec.

In experiments to determine the lower limit of the half-life the exposure period of the catcher was shortened to 3 sec while the transfer time was 1.5–2 sec. The results indicate that the half-life cannot be shorter than 2 sec.

In order to establish the mass number of the new isotope we attempted to determine the dependence of the cross section for its production on the bombarding energy, using 85-, 93-, and

98-Mev oxygen ions. In each instance the effect was too small to provide an exact excitation curve for the alpha activity of interest. It was established that the cross section increases considerably from 85-Mev to 93-Mev but is somewhat reduced above 93 Mev. In consideration of the cross sections for the (O^{16} , 4n) and (O^{16} , 5n) reactions in uranium,^{13,14} the foregoing results may be regarded as an indication that the reaction Pu^{241} (O^{16} , 4n) probably took place in our experiments, producing element 102²⁵³, although we cannot exclude the possibility that element 102²⁵⁴ was produced through a (O^{16} , 3n) reaction. It was shown by the experiments on lighter nuclei (V, Nb) described in reference 15 that this latter reaction possesses considerably greater probability than would follow from the simple theory of nucleon evaporation from a compound nucleus.

The cross section for the production of element 102 can be determined only tentatively since a number of imprecisely determined factors are involved. If we assume that the given isotope is subject only to alpha decay the cross section is of the order 5×10^{-32} cm², which is considerably smaller than the cross section obtained by the American investigators for the reaction Cm^{246} (C^{12} , 4n) 102²⁵⁴.

Pu^{239} was also bombarded with oxygen ions. In similar experiments during the autumn of 1957⁴ alpha particles with energies > 8.5 Mev were also detected, although their yield for an identical amount of target material was about one-seventh as large as in the case of Pu^{241} . In 20 three-hour bombardments, corresponding to three times as much ion current to the target as in the previous work, we detected only one 8.8-Mev alpha particle. What had been observed previously when Pu^{239} was bombarded was evidently entirely a background effect.

It must be remembered that when multiply-charged ions interact with heavy nuclei, protons or alpha particles may be emitted as well as neutrons. Therefore, when plutonium is bombarded with oxygen ions, mendelevium (Z=101) or fermium (Z=100) can be produced. According to the systematics of alpha-active nuclei, alpha particles with energies greater than 8.5 Mev can be emitted by isotopes of these elements that are lighter than Mv^{250} and Fm^{246} . However, when Pu^{241} is irradiated with O^{16} ions these isotopes can be produced only in reactions involving the emission of seven or more nucleons; this is energetically impossible when 98-Mev oxygen ions are used.

Of course, departures from the systematics might occur in the direction of increasing the alpha-decay energy of Mv and Fm isotopes, i.e.,

Mv^{251} or Fm^{247} could emit alpha particles having energies greater than 8.5 Mev. There is considerably greater probability that these isotopes will be produced when O^{16} interacts with Pu^{239} than with Pu^{241} . The fact that more rather than fewer alpha particles with higher energy (~8.9 Mev) result with Pu^{241} than with Pu^{239} leads us to infer that this emission cannot result from the decay of mendelevium or fermium isotopes.

At the Eighth Mendeleev Congress (in Moscow, March, 1959) A. Ghiorso reported preliminary results from the bombardment of Cm^{244} with C^{13} ions at the University of California. An isotope was produced having a half-life of 10 – 20 sec and emitting alpha particles with 8.8 ± 0.1 Mev, which the American workers attributed to the decay of 102²⁵³.

It is the pleasant duty of the authors to thank Academician I. V. Kurchatov for his extreme interest in the present work. We are grateful for the constant assistance rendered by Yu. B. Gerlit, L. I. Guseva, and K. V. Filippova of the Institute for Geochemistry and Analytic Chemistry and by Yu. V. Lobanov, V. L. Mikheev, V. P. Perelygin, A. P. Pleve, and G. M. Ter-Akopyan of the Joint Institute for Nuclear Research, as well as for the valuable aid in matters of technique which was rendered by K. S. Bogomolov and A. A. Sirotinskaya of the Motion Picture and Photography Research Institute, by D. G. Alkhozov of the Leningrad Institute of Physics and Technology and by S. P. Kalinin of the Institute of Atomic Energy.

¹G. Seaborg, Report at Second International Conference on the Peaceful Uses of Atomic Energy, Geneva, 1958; *Атомная энергия* (Atomic Energy) **6**, 21 (1959).

²Fields, Friedman, Milsted, Atterling, Forsling, Holm, and Aström, *Phys. Rev.* **107**, 1460 (1957).

³Ghiorso, Sikkeland, Walton, and Seaborg, *Phys. Rev. Letters* **1**, 17 (1958).

⁴Flerov, Polikanov, Karamyan, Pasyuk, Parfanovich, Tarantin, Karnaukhov, Druin, Volkov, Semchinova, Oganessian, Khalizev, and Khlebnikov, *Dokl. Akad. Nauk SSSR* **120**, 73 (1958), *Soviet Phys.-Doklady* **3**, 546 (1958).

⁵Ghiorso, Sikkeland, Walton, and Seaborg, *Phys. Rev. Letters* **1**, 18 (1958).

⁶Morozov, Makov, and Ioffe, *Атомная энергия* (Atomic Energy) **3**, 272 (1957).

⁷Yu. Ts. Oganessian, *JETP* **36**, 936 (1959), *Soviet Phys. JETP* **9**, 661 (1959).

⁸O. B. Firsov, *Dokl. Akad. Nauk SSSR* **91**, 515 (1953).

⁹R. B. Leachman and H. Atterling, *Arkiv Fysik* **13**, 101 (1958).

¹⁰ V. A. Karnaukhov and V. L. Mikheev, Приборы и техника эксперимента (Instruments and Measurement Engineering), in press.

¹¹ A. A. Sirotinskaya and K. S. Bogomolov, Тр. Всесоюзного научно-исследовательского кинофотоинститута (Trans. All-Union Motion Picture and Photography Research Institute) **2**, 66 (1958).

¹² Karnaukhov, Khalizev, and Flerov, JETP **37**, 1266 (1959), Soviet Phys. JETP **10**, 901 (1960).

¹³ Volkov, Guseva, Tarantin, Myasoedov, and

Filippova, JETP **36**, 1207 (1959), Soviet Phys. JETP **10**, 859 (1960).

¹⁴ Perelygin, Donets, and Flerov, JETP **37**, 1558 (1959), Soviet Phys. JETP **10**, 1106 (1960).

¹⁵ Karamyan, Gerlit, and Myasoedov, JETP **36**, 621 (1959), Soviet Phys. JETP **9**, 431 (1959).

Translated by I. Emin

15