

ANALYSIS OF THE OPTICAL SPECTRA OF $\text{CaF}_2:\text{Nd}^{3+}$ (Type 1) CRYSTALS¹⁾

Yu. K. VORON'KO, A. A. KAMINSKIĬ, and V. V. OSIKO

P. N. Lebedev Physics Institute, Academy of Sciences, U.S.S.R.

Submitted to JETP editor March 10, 1965

J. Exptl. Theoret. Phys. (U.S.S.R.) 49, 420-428 (August, 1965)

The new concentration-series method used to discriminate spectra belonging to different types of centers is utilized in the present work to analyze the optical spectra of rare earth ions in CaF_2 crystals (type 1). The spectra of Nd^{3+} in CaF_2 (type 1) are studied in the concentration range from 0.003 to 2.0 wt % of neodymium at temperatures from 300° to 4.2°K. An energy level scheme is constructed for three different types of centers. Our results are compared with EPR data. The Nd^{3+} centers participating in stimulated emission are identified.

INTRODUCTION

ALKALI fluorides activated by lanthanides (TR) occupy a special place in the extensive class of luminescent crystals. These fluoride crystals have recently been the objects of numerous spectroscopic investigations by different groups of authors. In connection with lasers considerably greater general interest has been aroused in the investigation of TR^{3+} and TR^{2+} ions in rare earth fluorides.

Among the most promising activators of different host crystals used in lasers is the trivalent neodymium ion. We at present know of about twenty different crystals doped with Nd^{3+} in which emission has been stimulated. The most fully investigated crystals containing Nd^{3+} for which the stimulated emission spectrum has been identified with absorption and fluorescence spectra are CaWO_4 ^[2-5] PbMoO_4 ^[6] and LaF_3 ^[7].

Emission at room temperature has recently been observed in $\text{CaF}_2:\text{Nd}^{3+}$ (type 1) at $\lambda = 10\,461\text{ \AA}$.^[8] Five more emission lines were observed from 90° to 15°K.^[9] We know that Nd^{3+} can be distributed in CaF_2 crystals among differently formed centers characterized by unlike spectra. The formation of any particular optical centers depends, among other factors, on the concentration of the activator in the CaF_2 crystals. The crystals in which stimulated emission was investigated contained from 0.07 to 1.0 wt % Nd^{3+} . The symmetry of the neighborhoods of different Nd^{3+} optical centers in CaF_2 was studied by means of electron paramagnetic resonance (EPR).

Thus it was found in^[10] that Nd^{3+} can be located in a crystal field exhibiting tetragonal symmetry and two kinds of rhombic symmetry. The intensity of the latter increases with the Nd^{3+} concentration. It was reported in^[11] that $\text{CaF}_2:\text{Nd}^{3+}$ crystals have a spectrum corresponding to a cubic crystalline electric field.

There have been several investigations of the optical spectra of Nd^{3+} in CaF_2 ; infrared fluorescence has been described in Feofilov's review article.^[12] In^[13] Kiss attempted to compare the observed absorption spectrum with the theoretical spectrum based on the assumption of a cubic field. It was impossible to identify the spectrum of stimulated emission and the emitting centers on the basis of these studies.

We have investigated the absorption, fluorescence, and stimulated emission spectra and have measured the lifetime of the excited Nd^{3+} state in CaF_2 (type 1). The Nd^{3+} concentration in these crystals varied from 0.003 to 2.0 wt %.

PREPARATION OF CRYSTALS

The $\text{CaF}_2:\text{Nd}^{3+}$ crystals were grown by lowering a crucible into a doped fluorinating atmosphere whose composition ensured the complete removal of extraneous oxygen compounds. The Nd^{3+} concentration varied from 0.003 to 2.0 wt %, as determined from the amount of NdF_3 (weighed with ± 0.5 mg accuracy). The graphite crucible was designed to permit the simultaneous growth of eight crystals having different neodymium concentrations (an entire concentration series). The crystals synthesized in this manner were under identical conditions during the entire process of growth and annealing, and differed only in the con-

¹⁾The designation of the type of crystal follows the crystal chemical classification of [1].

centration of the activator. The rate of linear growth was 36 mm/hr. Cylindrical samples of different sizes were cut from the grown crystals, which were 140 mm long and 12 mm in diameter, for the purpose of investigating absorption, fluorescence and stimulated emission. A spectrophotometric method was developed for controlling the Nd^{3+} concentration in the CaF_2 crystals. An analysis showed that the Nd^{3+} concentration in our crystals was exactly equal to the concentration in the original materials. It was also demonstrated photometrically that the neodymium was uniformly distributed throughout the volume of the crystal (lengthwise and diametrically).

ABSORPTION SPECTRUM

The absorption spectrum of $\text{CaF}_2:\text{Nd}^{3+}$ in the investigated crystals at 300°K is given in [8]. This spectrum consists of separate groups of lines corresponding to determinate electron transitions of the free Nd^{3+} ion.^[14] The number and spectral positions of the separate lines within the groups are determined by symmetry and by the strength of the crystal electric field in which the Nd^{3+} ions are located.

A detailed investigation of Nd^{3+} absorption in individual groups was performed with high-resolution apparatus at 77° and 4.2°K. The absorption spectra at 4.2°K were photographed with a DFS-13 diffraction spectrograph having a grating of 1200 lines/mm and ~ 1.7 Å/mm dispersion. The crystals were immersed directly in liquid helium. The sources of the visible light were tungsten motion-picture lamps; for the near ultraviolet region a DKSSh-250 ultrahigh-pressure xenon lamp was used. At 77°K the spectra were studied with a DFS-12 diffraction spectrometer having gratings of 600 lines/mm with 0.1 Å resolution. Light passing through the crystal impinged on either an FÉU-17 photomultiplier with a cesium-antimony photocathode or an FÉU-22 photomultiplier with a cesium-oxide photocathode. Figure 1 shows the scheme of the cryostat with the light source and the crystal. The light source here was a tungsten incandescent lamp stabilized at 6.3 W and 1.8 V input. The lamp and crystal were immersed in liquid nitrogen. Light that had traversed the crystal was conducted through a quartz light pipe to the entrance slit of the spectrometer. For the quantitative treatment of the absorption spectra we verified in advance the linearity of the measuring-system readings of output signals.

For convenience in subsequent interpretations of the $\text{CaF}_2:\text{Nd}^{3+}$ absorption spectrum we selected

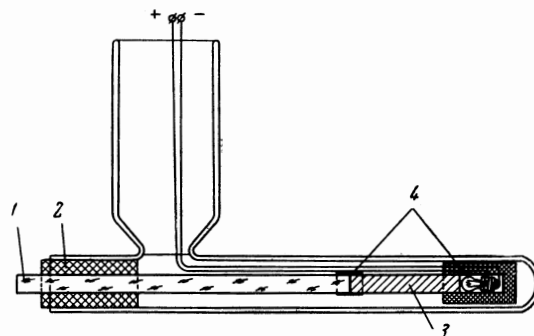

FIG. 1. Scheme of the cryostat. 1 – quartz light pipe, 2 – foam plastic plug, 3 – crystal, 4 – teflon connectors.

a few groups of lines having minimum values of J in the different spectral regions. These groups represent transitions from the $^4I_{9/2}$ ground level to the following levels: $^4F_{3/2}$ (11 500 cm^{-1}), $^4F_{5/2}$ and $^2H_{9/2}$ (12 500 cm^{-1}), $^4F_{7/2}$ and $^4S_{3/2}$ (13 500 cm^{-1}), $^2P_{1/2}$ (23 500 cm^{-1}), and $^4D_{3/2}$ (26 000 cm^{-1}). Three of these transitions are represented in Fig. 2. With increasing Nd^{3+} concentration the structure of the groups is seen to change considerably; the number of lines increases and their relative intensities are altered. The total number of lines in the groups is smaller at 4.2°K than at 77°K. It should be noted that in the absorption spectra obtained at 4.2°K the main lines are accompanied by a set of weak lines varying in width, which are entirely absent from the spectra obtained at 77°K.

FLUORESCENCE SPECTRUM

The $\text{CaF}_2:\text{Nd}^{3+}$ fluorescence spectrum was investigated at 77°K with a DFS-12 diffraction spectrometer. Fluorescence was excited with the aid of an elliptic illuminator having in one of its focal regions a tubular glass cryostat containing the object crystal, and at the other focus a tungsten motion-picture lamp of stabilized 300 or 500 W input. Emission from the crystal was conducted by a quartz light pipe to the entrance slit of the DFS-12 spectrometer and was ultimately detected by a calibrated FÉU-22 photomultiplier.

We know that Nd^{3+} fluoresces in the infrared region at 0.9, 1.05, 1.35, and 1.8 μ . We studied this fluorescence at 0.9 and 1.05 μ , corresponding to the transitions $^4F_{3/2} \rightarrow ^4I_{9/2}$ (8600 – 9200 Å) and $^4F_{3/2} \rightarrow ^4I_{11/2}$ (10 350–11 000 Å) (Fig. 3). A characteristic feature of these spectra, as in the case of the aforementioned absorption spectra, is observed in the changing relative intensities of the lines as the Nd^{3+} concentration increases.

The lifetime of the excited state of $\text{CaF}_2:\text{Nd}^{3+}$ crystals was investigated at temperatures from

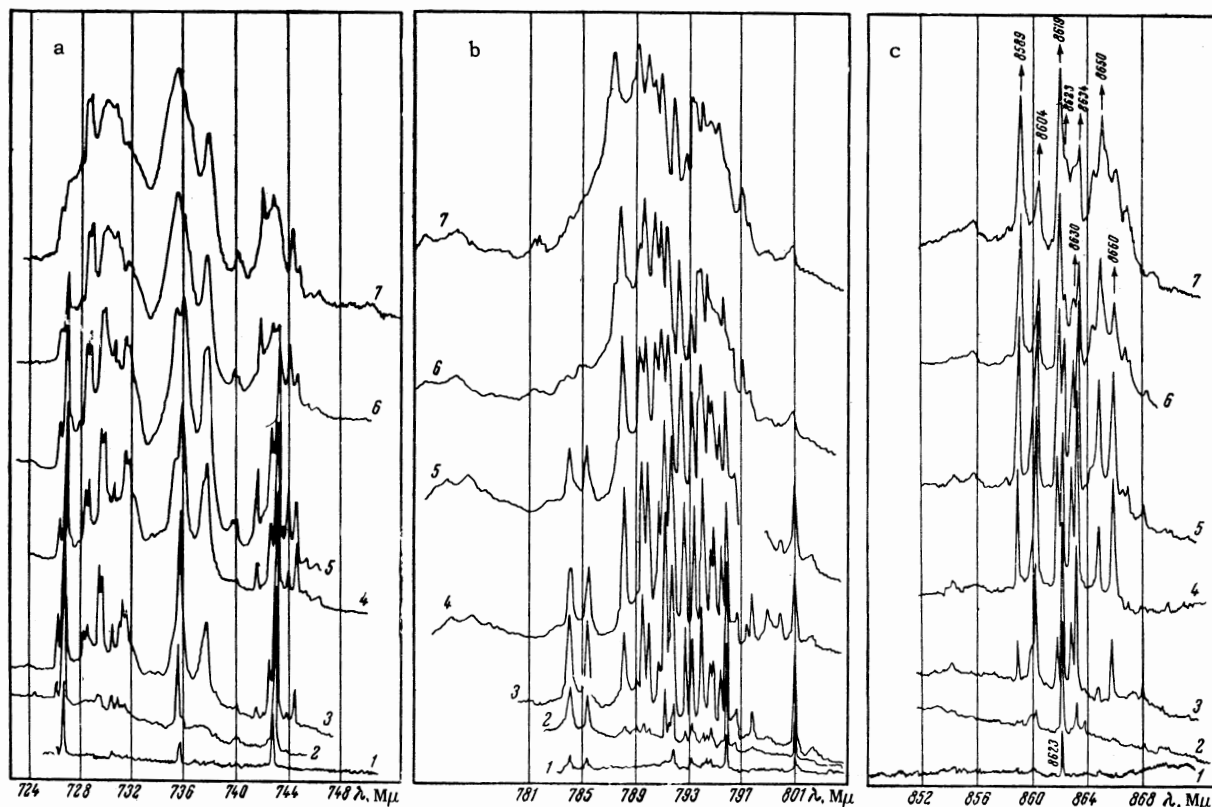

FIG. 2. Absorption spectra of $\text{CaF}_2:\text{Nd}^{3+}$ at 77°K . The represented transitions are : a) ${}^4\text{P}_{3/2} \rightarrow {}^4\text{S}_{3/2}$, ${}^4\text{F}_{7/2}$; b) ${}^4\text{P}_{3/2} \rightarrow {}^2\text{H}_{7/2}$, ${}^4\text{F}_{5/2}$; c) ${}^4\text{P}_{3/2} \rightarrow {}^4\text{F}_{3/2}$. The Nd^{3+} concentrations (wt %) are: 1 - 0.003, 2 - 0.01, 3 - 0.03, 4 - 0.1, 5 - 0.3, 6 - 1.0, 7 - 2.

300° to 4.2°K .^[15] The results show that the fluorescence decay curves can be fitted on two exponentials, whose contributions to the combined curve vary with the Nd^{3+} concentration. At 77°K the fluorescence decay time is somewhat longer than at 300°K ; this is evidence for nonradiative transitions from the ${}^4\text{F}_{3/2}$ level. In crystals having $\sim 0.5\%$ neodymium the lifetime of the excited ${}^4\text{F}_{3/2}$ state at 300°K was 0.8 and 1.15 msec; at 77°K and at a lower temperature the lifetimes were 0.95 and 1.4 msec. These data yielded the lifetime of nonradiative transitions from the ${}^4\text{F}_{3/2}$ level at 300°K . The respective values are ~ 9 msec and ~ 6.5 msec.

STIMULATED EMISSION SPECTRUM

As already mentioned, stimulated emission from the $\text{CaF}_2:\text{Nd}^{3+}$ crystals grown by the previously described method was registered at both 77°K and 300°K . The spectrum of the ${}^4\text{F}_{3/2} \rightarrow {}^4\text{I}_{11/2}$ transition had been investigated in the broad temperature range $300^\circ - 15^\circ\text{K}$.^[9] Emission was observed in samples containing from 0.07 to 0.7 wt % Nd^{3+} . When the concentration was 0.02 wt % emission was absent even at 15°K and high excitation energies. At 300°K the emitted wavelength was $10\,461\text{ \AA}$ (9559 cm^{-1}) for all these crystals.

For other crystals at temperatures reduced to the range $50^\circ - 15^\circ\text{K}$ the spectrum was enriched with five new lines at $10\,447.6\text{ \AA}$ (9571.6 cm^{-1}), $10\,456.2\text{ \AA}$ (9563.7 cm^{-1}), $10\,466\text{ \AA}$ (9554.7 cm^{-1}), $10\,480\text{ \AA}$ (9541 cm^{-1}), $10\,506.5\text{ \AA}$ (9518 cm^{-1}), and $10\,648\text{ \AA}$ (9391 cm^{-1}). The emission line present at 300°K is shifted towards shorter wavelengths by about 5 \AA at low temperatures. Three lines were observed at 77°K for all crystals except the samples containing 0.07 wt % Nd^{3+} ; the wavelengths are $10\,447.6$, $10\,456.2$, and $10\,466\text{ \AA}$. The crystals containing $\sim 0.07\text{ wt \% Nd}^{3+}$ emitted only two lines ($10\,456.2$ and $10\,466\text{ \AA}$) up to 20°K . With decreasing temperature the intensity of the $10\,456.2\text{-\AA}$ line was observed to decrease; below 18°K this line disappeared completely.

DISCUSSION OF RESULTS

For the $4f^3$ configuration of Nd^{3+} the total number of possible terms was 17, including 5 terms of the higher multiplicity. These terms are denoted by ${}^2\text{P}2\text{D}2\text{F}2\text{G}2\text{H}2\text{K}2\text{L}$ and ${}^4\text{SDFGI}$.^[14] The number of levels with different values of J is 41. We know that the spectral positions and the number of individual absorption groups of $\text{CaF}_2:\text{Nd}^{3+}$ are quite consistent with the transitions of the free neodymium ion. The number of

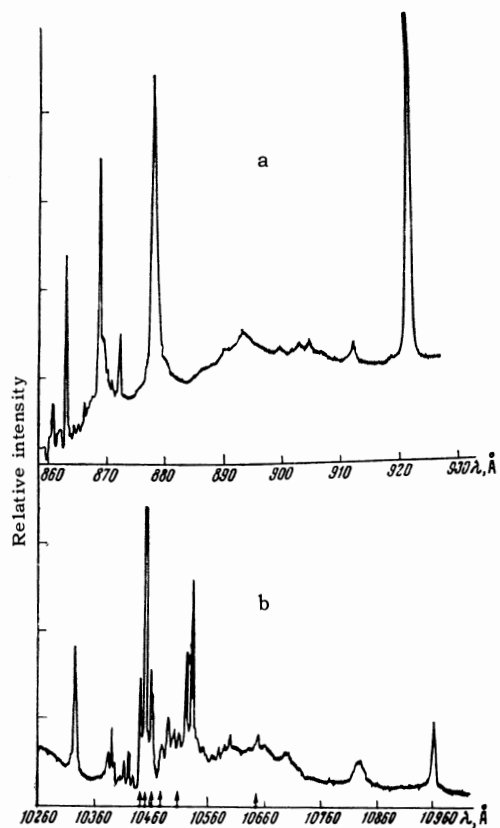

FIG. 3. Fluorescence spectra of $\text{CaF}_2:\text{Nd}^{3+}$ at 77°K . The transitions are : a) ${}^4\text{F}_{3/2} \rightarrow {}^4\text{P}_{1/2}$ (0.3 wt % Nd^{3+}); b) ${}^4\text{F}_{3/2} \rightarrow {}^4\text{I}_{1/2}$ (1.0 wt % Nd^{3+}). Lines present in the stimulated emission spectrum are indicated by arrows.

these lines in the separate groups even at helium temperatures considerably exceeds the theoretically computed number when it is assumed that all neodymium ions experience identical conditions in the crystals. This discrepancy is caused by the fact that in actuality the neodymium ions in a fluorite lattice are located in several types of centers having different structures.

One of the present authors^[16] performed an approximate thermodynamic calculation of the equilibrium of TR^{3+} optical centers in CaF_2 (type 1) crystals. Relations were derived between the concentrations of a few different types of TR^{3+} centers having different structures and both the equilibrium temperature and total rare earth concentration. Figure 4 shows the isotherms of absolute concentrations of cubic, tetragonal, and rhombic centers. The concentration dependences of the different centers are very distinctly different. This circumstance allows the analysis of optical $\text{CaF}_2:\text{TR}^{3+}$ spectra from the concentration dependences of line intensities corresponding to transitions between the Stark components of different levels.

Figure 5 represents an analysis of the

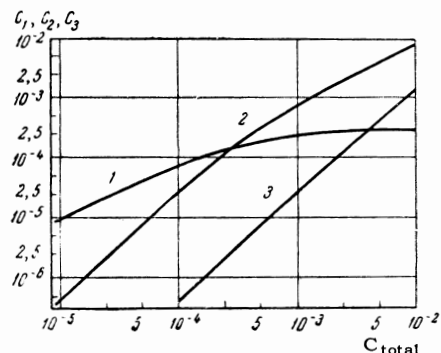

FIG. 4. Theoretical isotherms of the absolute concentrations of neodymium centers in CaF_2 crystals. Curve 1 – cubic centers, 2 – tetragonal centers, 3 – rhombic centers. The abscissa scale represents the total concentration of the rare earth ion; the ordinate scale represents the concentration of different centers for the equilibrium temperature 1373°K .

$\text{CaF}_2:\text{Nd}^{3+}$ absorption spectra. A log-log scale has been used to plot the absorption coefficients at the maximum of individual lines as functions of the Nd^{3+} concentration. This was done for only a few of the lines in order to avoid overcrowding of the figure. The appropriate wavelengths are indicated on the curves of Fig. 5 and the lines of Fig. 2.

A comparison of the curves shows clearly that they all fall into three systems designated by L, M, and N in the figure. Each of these systems is a family of parallel curves. These systems of lines obviously belong to centers having different structures.

The curves were plotted for all absorption lines with the exception of very weak lines that did not permit an accurate determination of the absorption coefficients. The absorption coefficients were determined only for those Nd^{3+} concentrations at which line broadening was not yet

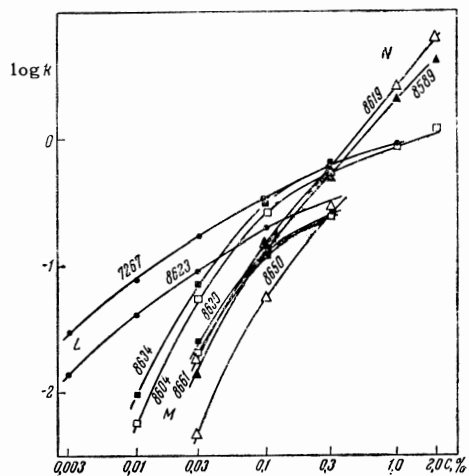

FIG. 5. Absorption coefficients at λ_{max} for lines of the ${}^4\text{F}_{3/2}$, ${}^2\text{H}_{9/2}$, and ${}^4\text{F}_{5/2}$ groups versus concentration.

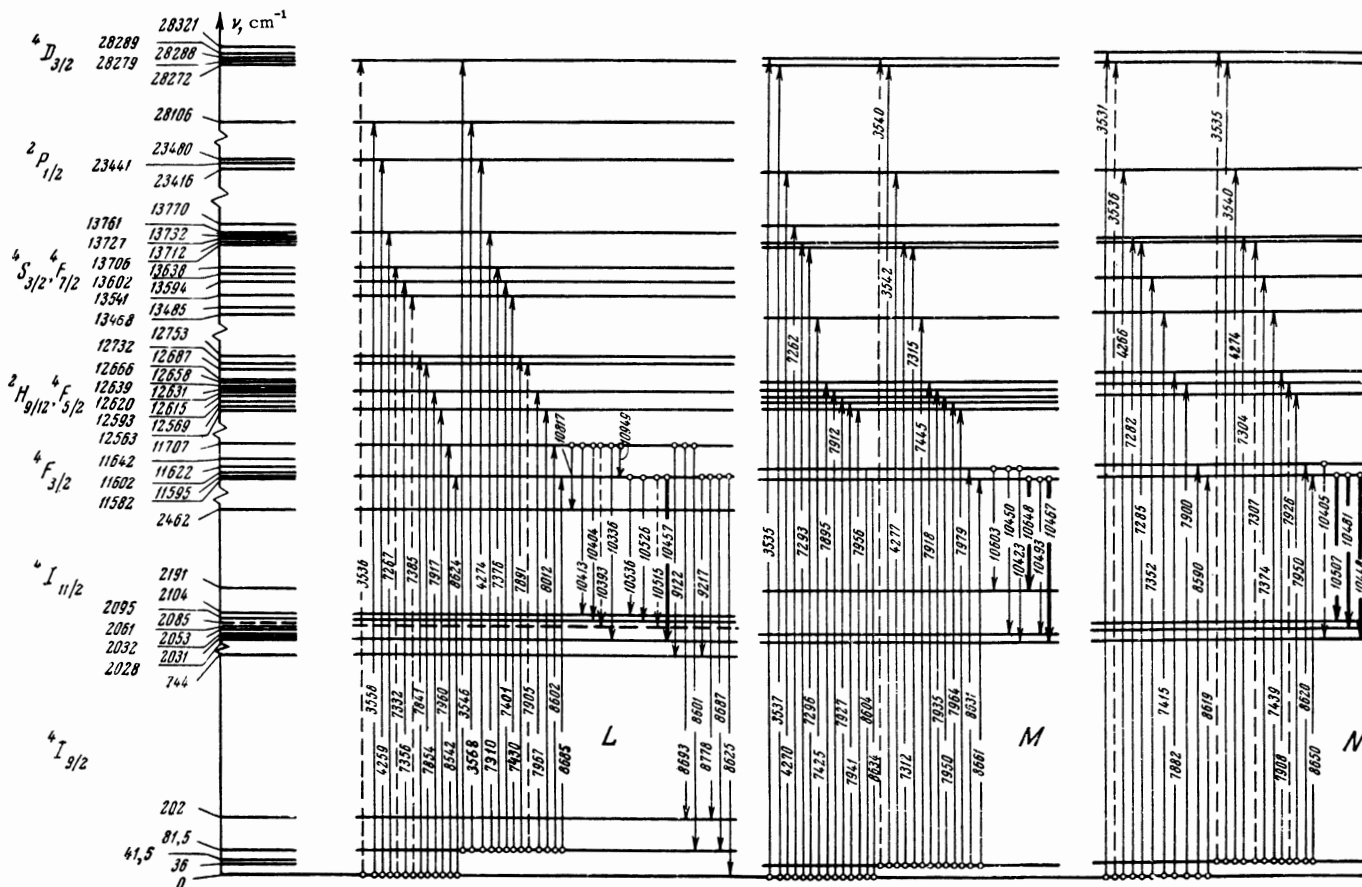

FIG. 6. Level scheme of Nd^{3+} in CaF_2 (type 1) for the three types of centers.

observed. As in the case of the absorption spectra, the fluorescence spectra exhibit three systems of lines belonging to the three different types of Nd^{3+} centers.

From the comparison of the absorption, fluorescence, and stimulated emission spectra at room, nitrogen, and helium temperatures we were enabled to construct the energy level schemes for each of these centers (Fig. 6). The positions of the levels were determined to within ± 1.5 cm. The distance to the first excited level of the $^4I_{9/2}$ ground state is 81.5 cm^{-1} for L centers, 36 cm^{-1} for M centers, and 41.5 cm^{-1} for N centers. The lowest level $^4F_{3/2}$ of the 4F term, which is the initial level for infrared fluorescence and stimulated emission, consists of two Stark components for all centers. Approximately ~ 40 cm^{-1} splitting of the $^4F_{3/2}$ level occurs for both the M and N centers; the splitting of this level for the L spectrum is ~ 112 cm^{-1} . The Stark splittings of the other levels ($^2H_{9/2}$; $^4F_{5/2}$), ($^4S_{3/2}$; $^4F_{7/2}$), $^2P_{1/2}$, and $^4D_{3/2}$ are shown in the level scheme. The transitions denoted by dashed lines correspond to insufficiently clear lines in the absorption and fluorescence spectra.

Thus our analysis of the optical spectra of Nd^{3+} in CaF_2 enabled us to discriminate systems of lines belonging to three different types of centers and to construct the energy level schemes for these centers. However, the structures of these centers cannot be identified confidently on the basis of the foregoing analysis alone; data obtained by other methods must also be considered.

The EPR spectra of the neodymium ion in CaF_2 ,^[10] investigated in the same samples that were used in the present work, show that some of the neodymium ions are in a tetragonal crystal field, while others are in two different fields of rhombic symmetry. Relaxation studies showed that the first excited level of the $^4I_{9/2}$ ground state lies 74 ± 5 cm^{-1} above the base level for the tetragonal spectrum; the corresponding levels for the two rhombic spectra are 43 ± 4 cm^{-1} and 24 ± 5 cm^{-1} .

In comparing our data with the EPR results we can assume that the L spectrum belongs to the tetragonal centers, the M spectrum to the centers of rhombic symmetry I, and the N spectrum to centers of rhombic symmetry II.

In Fig. 6 the stimulated transitions are denoted

by heavy lines. It has already been mentioned that at low temperatures the stimulated line from the ${}^4F_{3/2}$ level of the L spectrum becomes weaker and disappears completely at 18°K. This result can be accounted for by the fact that at low temperatures strong absorption is observed at the frequency emitted in a transition from the 11 595 cm^{-1} metastable level to one of the Stark components of the ${}^4G_{9/2}$ level lying 21 154 cm^{-1} above the ground level. At 300°K the absorption coefficient of the ${}^4G_{9/2}$ level for the 9559- cm^{-1} emission from the 11 595 cm^{-1} level has the small value $\sim 0.0005 \text{ cm}^{-1}$ (this is a broad diffuse line). At 77°K the absorption line is narrowed, while its center and the center of the emitted line are shifted somewhat. In this case the absorption coefficient has become $\sim 0.02 \text{ cm}^{-1}$. At lower temperatures these lines are shifted further and emission at 10 456.2 Å becomes impossible.

The authors wish to thank A. M. Prokhorov and Kh. S. Bagdasarov for discussions of the results, V. B. Aleksandrov for experimental assistance, and S. P. Afanas'ev for assisting with the crystal synthesis.

¹V. V. Osiko, in *Rost kristallov (Growth of Crystals)* 5, AN SSSR, 1965.

²L. F. Johnson and K. Nassau, *Proc. IRE* **49**, 1704 (1961).

³Johnson, Boyd, Nassau, and Soden, *Phys. Rev.* **126**, 1406 (1962).

⁴L. F. Johnson and R. A. Thomas, *Phys. Rev.* **131**, 2038 (1963).

⁵Kariss, Morozov, and Feofilov, *Opt. i Spektroskopiya* **17**, 887 (1964).

⁶Ya. É. Kariss and P. P. Feofilov, *Opt. i Spektroskopiya* **17**, 718 (1964).

⁷L. F. Johnson, *J. Appl. Phys.* **34**, 897 (1963).

⁸Kaminskiĭ, Kornienko, Makarenko, Prokhorov, and Fursikov, *JETP* **46**, 386 (1964), *Soviet Phys. JETP* **19**, 262 (1964).

⁹Kaminskiĭ, Kornienko, and Prokhorov, *JETP* **48**, 476 (1965), *Soviet Phys. JETP* **21**, 318 (1965).

¹⁰Kask, Kornienko, and Fakir, *FTT* **6**, 549 (1964), *Soviet Phys. Solid State* **6**, 430 (1964).

¹¹G. Vincow and W. Low, *Phys. Rev.* **122**, 1390 (1961).

¹²P. P. Feofilov, *Izv. AN SSSR, Ser. fiz.* **26**, 435 (1962), *Columbia Tech. Transl.* p. 437.

¹³Z. J. Kiss, *J. Chem. Phys.* **38**, 1476 (1963).

¹⁴M. A. El'yashevich, *Spektry redkikh zemel' (Spectra of the Rare Earths)*, Gostekhizdat, 1953.

¹⁵Kaminskiĭ, Kornienko, and Prokhorov, *JETP* **48**, 1262 (1965), *Soviet Phys. JETP* **21**, 844 (1965).

¹⁶V. V. Osiko, *FTT* **7**, 1294 (1965), *Soviet Phys. Solid State* **7**, 1047 (1965).

Translated by I. Emin